

ionmax

# SELAH

# AIR PURIFIER

ION360



USER MANUAL

## DEAR CUSTOMER

Thank you for purchasing the Ionmax Selah ION360 UV HEPA Air Purifier. The Ionmax Selah can help to improve the indoor air quality in your home or office.

Please read this manual carefully before use to ensure proper usage and save these instructions for future reference.

This package includes:

- Ionmax Selah ION360 Air Purifier
- User Manual

**Note:** Remove plastic bags from air purifier and filter before first use.

## CONTENTS

SAFETY INSTRUCTIONS	3
PRODUCT DIAGRAM	4
SPECIFICATIONS	4
PURIFICATION SYSTEM	5
CONTROL PANEL	6
OPERATING INSTRUCTIONS	7
MAINTENANCE INSTRUCTIONS	8
FILTER REPLACEMENT	8
TROUBLESHOOTING GUIDE	9
WARRANTY DETAILS	10
WARRANTY REGISTRATION	11



### **PLEASE READ ALL THE TIPS AND WARNINGS BELOW BEFORE USING THE AIR PURIFIER**

- Use only as directed in the User Manual.
- Do not allow children or persons with reduced physical, sensory, or mental capabilities to operate the unit without adult supervision.
- Only designed for use in a 220-240V, 50/60Hz outlet.
- This product is intended for domestic indoor use only.
- Only operate the unit when it is fully assembled.
- Never touch the unit with wet hands or allow it to come into contact with water.
- Turn off all controls before unplugging the power supply.
- Always disconnect the unit from the power supply before moving or cleaning the unit, and when the unit is not in use.
- When removing the power plug, always hold the plug and never pull the cord.
- This air purifier is not a substitute for proper ventilation, regular vacuum cleaning or an extractor hood or fan while cooking.
- Leave at least 30cm of space behind and on both sides of the unit and leave at least 30cm space above the unit.
- Do not use the unit in bathrooms, kitchens, humid areas, near fireplaces, or place it in proximity to flammable or combustible products, as electric shock and a fire hazard may result.
- Do not clean the unit with water or any other liquid including flammable products.
- Do not run power cord under carpeting, or cover with rugs or runners. Arrange the cord away from areas where it may be tripped over.
- Never operate the unit if the plug or cord appears damaged. Contact the authorised distributor or qualified personnel immediately for examination and repair.
- Do not insert fingers or foreign objects into the air intake or air outlet, or block them by placing items on the air outlet or in front of the air intake.
- Do not place anything on top of the unit and do not sit on the unit.
- Do not place the unit directly below an air conditioner as condensation may drip into the unit.
- Do not operate this unit when using indoor insect repellents (aerosols) or in places with oily residues, burning incense or chemical fumes.
- Do not use the unit in a room with major temperature changes, as this may cause condensation inside the unit.

## PRODUCT DIAGRAM

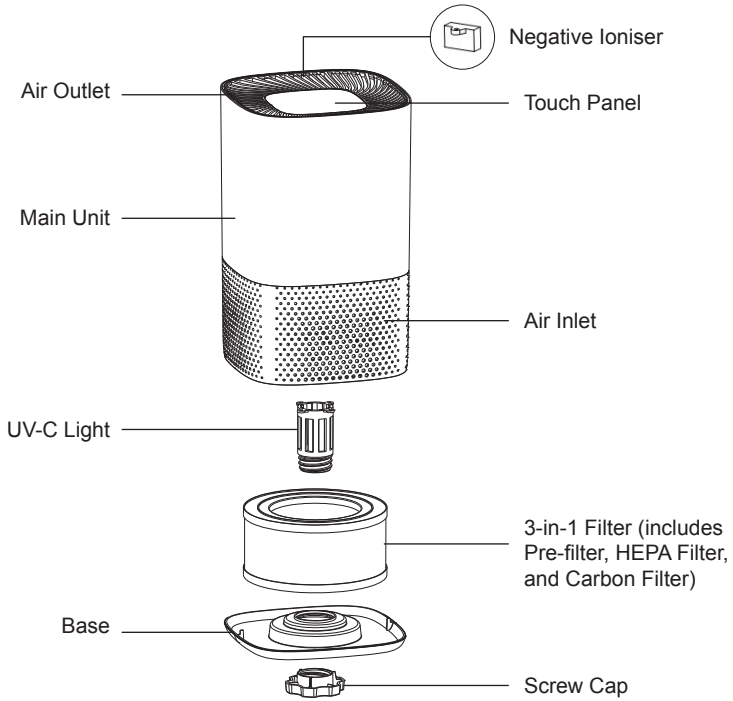

## SPECIFICATIONS

<b>Model</b>	Ionmax ION360
<b>Voltage</b>	220-240V, 50/60Hz
<b>Power Rating</b>	45W
<b>Coverage Area</b>	Up to 15 m <sup>2</sup>
<b>Germs Killed</b>	99%
<b>Noise Level</b>	Low: 30dB, High: 55dB
<b>Air Flow</b>	60CFM (102m <sup>3</sup> /h)
<b>Filter Life</b>	6 months (based on typical use)
<b>Weight</b>	2.78 KG
<b>Dimensions</b>	202 (W) x 204 (D) x 330 (H) mm

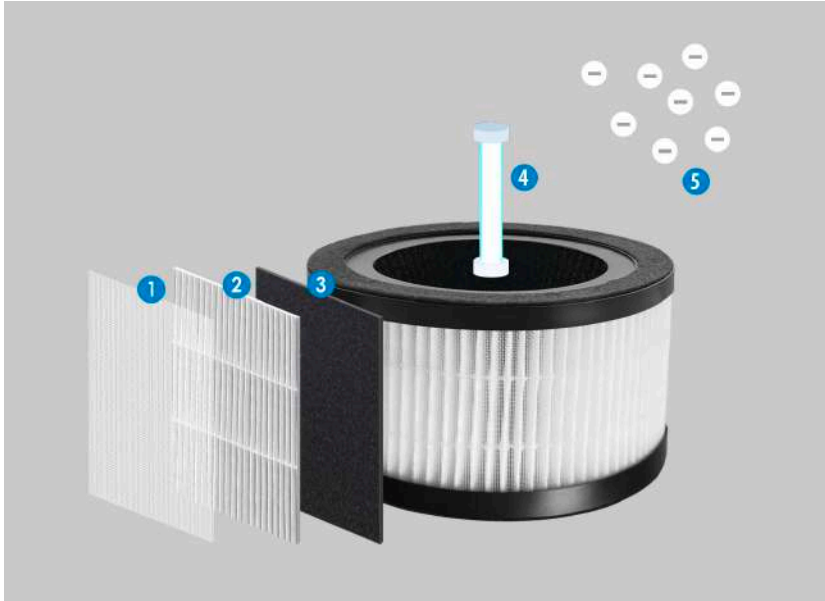

The Pre-Filter, HEPA Filter and Activated Carbon Filter are combined into one easy-to-change filter.

**1. Pre-Filter**

Traps large particles such as human hair, pet dander and dust particles. Helps to extend the life of the HEPA and Activated Carbon filters.

**2. HEPA Filter**

Traps up to 95% of allergens and airborne contaminants down to 0.3 microns in size. These allergens include lung damaging dust, mould spores, plant spores, pet dander and pollen.

**3. Activated Carbon Filter**

Absorbs and neutralises odours and other Volatile Organic Compounds (VOC's) such as formaldehyde and benzene, as well as other harmful fumes emitted by household products.

**4. UV-C Light (254nm)**

Destroys 99% microorganisms such as germs, viruses, bacteria and fungi (such as mould toxins).

**5. Negative Ions**

Improve indoor air quality by combining with dust or reacting with odour molecules and removing them from the air we breathe.

## CONTROL PANEL

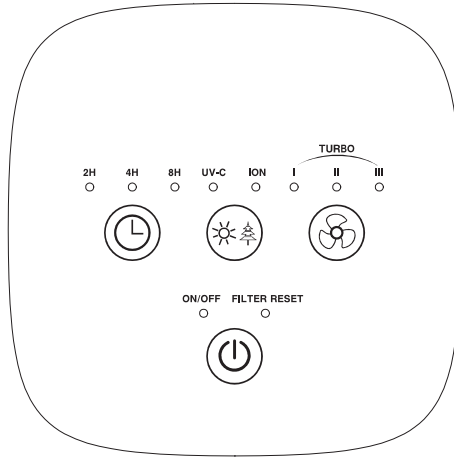

### “POWER” BUTTON

Press this button to turn the air purifier on or off.

Note: Press and hold Power Button for 3-5 seconds to reset the Filter Reset Indicator.



### “TIMER” BUTTON

The air purifier can be timed to operate for intervals of 2, 4, or 8 hours, stopping automatically when the selected operating time has elapsed.

To select continuous operating mode, press the button repeatedly until all three timer lights are off.

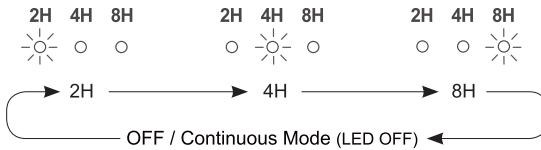

### “UV/ION” BUTTON

Press this button to turn the UV lamp and ION function on or off.

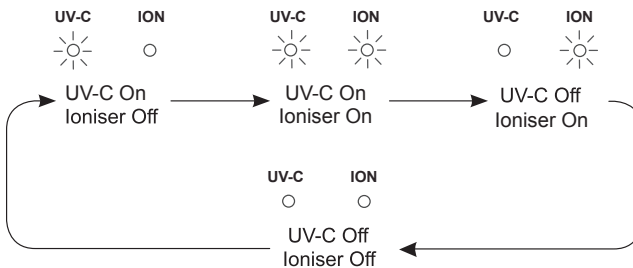



## “SPEED” BUTTON

The fan speed of the unit can be adjusted between Low (I), Medium (II), High (III) and Turbo when the unit is in operation.

The corresponding fan speed indicator will light up to indicate the current fan speed.

Note: If Turbo is selected, all the three fan speed indicators will light up.

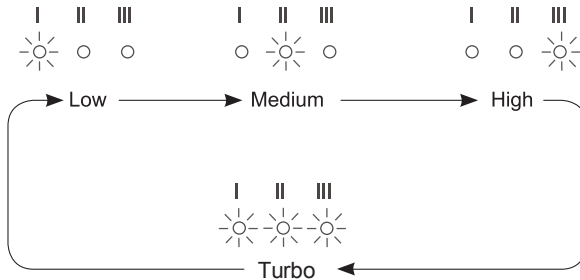

**FILTER REPLACEMENT** See page 8.

## OPERATING INSTRUCTIONS

**Note:** Remove plastic bags from air purifier and filter before first use.

1. Plug the appliance into a suitable electrical outlet.
2. Ensure the appliance is placed on a stable, flat and level surface.  
**Note:** For proper air flow, ensure the appliance is 30cm away from any wall or furniture and ensure that the air inlet and outlet is not blocked.
3. Press the power button to turn the appliance on.
4. Change the timer, fan speed, or UV/ION settings if desired (refer to Control Panel description).
5. Press the power button to turn the appliance off.

**Important note:** When the unit is not in use, switch it off and unplug it.

## MAINTENANCE INSTRUCTIONS

### CLEANING THE UNIT

- Always unplug the power supply before cleaning the unit.
- Do not put the unit into water or use water to wash it directly.
- Do not use any corrosive or flammable detergent to clean the unit.
- Use a soft cloth with mild cleanser to clean the unit, and make sure the unit is completely dry after cleaning.
- Regularly clean the inside and surface, to prevent dust from gathering.
- Regularly clean the air intake and air outlet.
- To maintain or replace filters, see below.

### STORAGE INSTRUCTIONS

If the unit will not be in use for a long time, please pack and store it properly:

- Unplug the power supply of the unit.
- Clean the filter.
- Use a soft cloth to clean the air intake and air outlet.

### CAUTION

- Proper use and regular maintenance can ensure efficient operation and extend the life of the unit.
- Do not attempt to repair or adjust any electrical or mechanical functions on this unit. All servicing should be performed by qualified personnel only.

## FILTER REPLACEMENT

### FILTER RESET INDICATOR

When the "FILTER RESET" indicator turns red during operation, it indicates that the 3-in-1 filter needs to be replaced.

Follow the instructions below on replacing the filters.

**Note:** The 3-in-1 filter can be used for about 6 months if used continuously, but its actual life depends on air quality condition and proper maintenance.

### REPLACING THE FILTERS

1. Ensure the unit is switched off. Turn the unit upside down.
2. Unscrew and remove the screw cap on the base of the unit.
3. Remove the base of the unit and remove the old filter.
4. Replace with a new filter (remove any plastic packaging beforehand).
5. Reattach the base onto the unit and fasten it with the screw cap.



6. Position the unit back on to its base.
7. Press the power button to switch the unit on. Then, press and hold the power button for 5 seconds to reset the "FILTER RESET" indicator light.

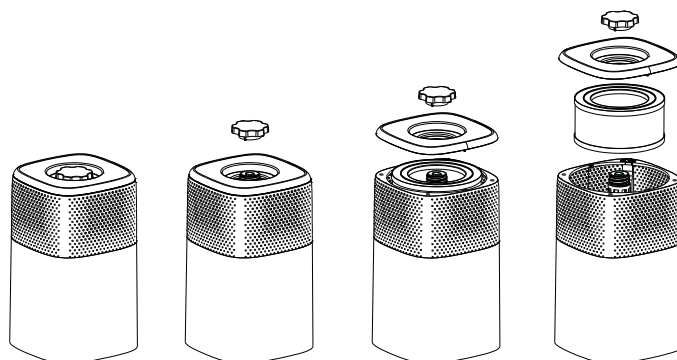

## FILTER MAINTENANCE

- The 3-in-1 filter is not washable.
- Do not use any solutions, brushes or sharp objects to clean the filter, as this can damage it.
- It can be gently vacuumed using hand tool attachments (no rotating brushes) once a month.

## TROUBLESHOOTING GUIDE

Problem	Probable Cause	Solution
Unit not operating	Power cable not plugged in	Plug in power cable
	Power cable not plugged in properly	Plug in power cable correctly
Loud noise	Filter not unpacked from plastic bag	Unpack the filter packaging
	Filter is dirty	Clean or replace the filter
Abnormal noise	Loose parts inside the unit	Contact customer service centre
	Motor broken	
Indicator lights not switched on	Product circuit control failure	Contact customer service centre
UV-C or ION indicator light is off	UV-C or ION is switched off	Press the UV/ION button
	UV-C or ION light is broken or needs replacement	Contact customer service centre
Reduced airflow	Filter is dirty	Clean or replace the filter
	Filter is dirty	Unpack the filter packaging

# WARRANTY DETAILS

**Congratulations on your purchase!** It is our aim to provide you with quality products that you can trust. Our products come with guarantees that cannot be excluded under the Australian Consumer Law. You are entitled to a replacement or a refund for a major failure and for compensation for any other reasonably foreseeable loss or damage. You are also entitled to have the goods repaired or replaced if the goods fail to be of acceptable quality and the failure does not amount to a major failure.

## The Guarantee

The product is guaranteed to be free from defects in workmanship and parts for a period of 12 months from date of purchase. Defects that occur within this warranty period, under normal use and care, will be repaired, replaced or refunded at our discretion, solely at our option with no charge for parts and labour. The benefits conferred by this warranty are in addition to all rights and remedies in respect of the product that the consumer has under the Trade Practices Act and similar state laws.

## Proof of Purchase

This warranty is valid for the original purchase and is not transferable. Please keep your purchase docket or receipt as proof of purchase and as proof of date on which the purchase was made. The purchase docket (or a copy) or receipt must be presented with the warranty when making a claim under this warranty.

## Service during the Warranty Period

To claim for warranty, contact us on 1300 800 200 or [support@andatech.com.au](mailto:support@andatech.com.au) to get an RA# (Return Authorisation Number) or submit a support ticket on [my.andatech.com.au](http://my.andatech.com.au). Ensure that the RA# is clearly stated on the outside of the packaging and that the product is properly packaged so that no damage occurs to the product during transit. Shipping of the product back to us for warranty will be at your cost. A product return without the RA# or proof of purchase will not be accepted.

## Extent of Warranty

This warranty is limited to defects in workmanship or parts. All defective products or parts will be repaired or replaced. This warranty does not cover manuals and packaging.

## Normal Wear and Tear

This warranty does not cover normal wear and tear to the product or parts.

## Exclusions

This warranty does not cover:

- Any defect caused by an accident, misuse, abuse, improper operation, lack of reasonable care, unauthorised modification, loss of parts, tampering or attempted repair by a person not authorised by the distributor.
- Any product that has been damaged by a lightning strike either directly or indirectly or a main power surge or liquid ingress.
- The product if it is located outside of Australia.
- Any damage caused by improper power input or improper cable connection.

---

## Andatech Pty. Ltd.

PO Box 3038, Nunawading VIC 3131, Australia.  
Phone: 1300 800 200 Fax: 1300 883 802 Email: [support@andatech.com.au](mailto:support@andatech.com.au)



# WARRANTY REGISTRATION

Register your Ionmax Selah Ion360 online at [my.andatech.com.au](http://my.andatech.com.au) or fill out this form and forward to the address below with a copy of your proof of purchase. Contact us on 1300 800 200 or email [support@andatech.com.au](mailto:support@andatech.com.au) for options to extend your warranty.

**Andatech Pty Ltd**

**PO Box 3038, Nunawading VIC 3131, Australia.**

Product	:	<b>Ionmax Selah Ion360</b>
Date of Purchase	:	_____
Place of Purchase	:	_____
Serial No.	:	_____
Surname	:	_____
Given Name	:	_____
Address	:	_____
Suburb	:	_____
Postcode	:	_____
State	:	_____
Contact No.	:	_____
Email	:	_____





[andatechdistribution.com.au](http://andatechdistribution.com.au)  
1300 800 200

Version 1.0. Updated July 2020.